

Typical Reinforced Wall Section

Near Vertical Setback

Place Additional Pieces of Geogrid When Angle Exceeds 20 degs.

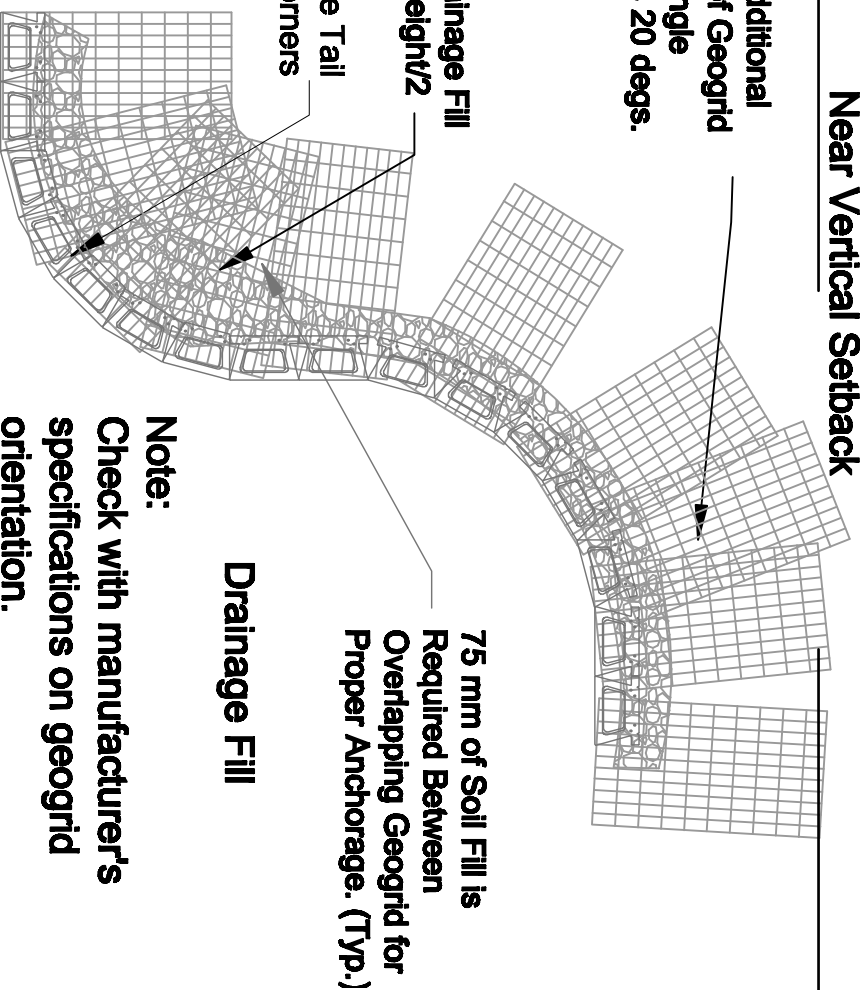

Note:
Check with manufacturer's specifications on geogrid orientation.

Geogrid Installation on Curves

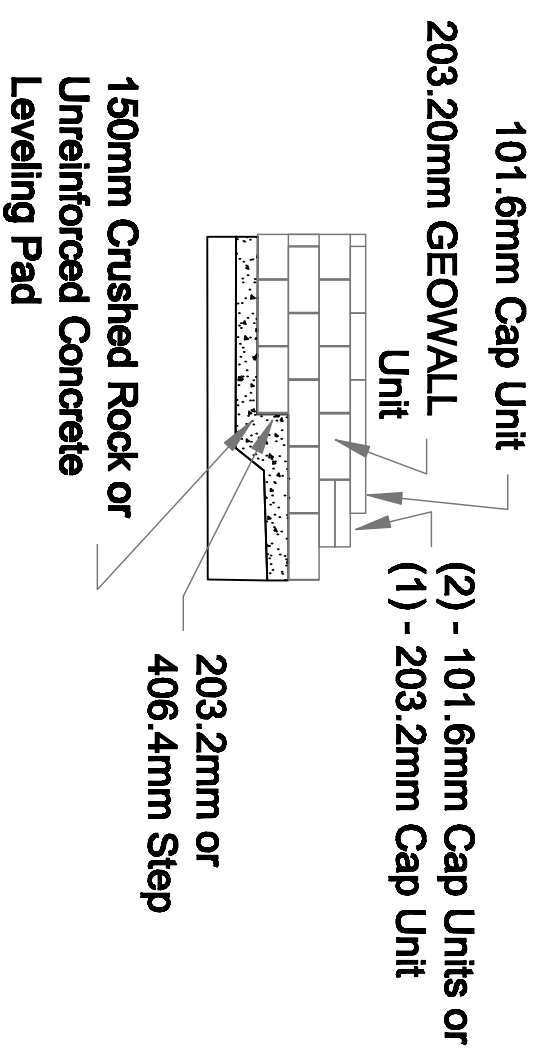

Glue cap units to wall units

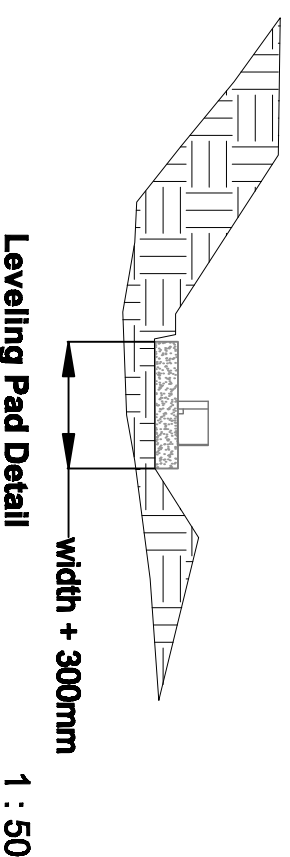
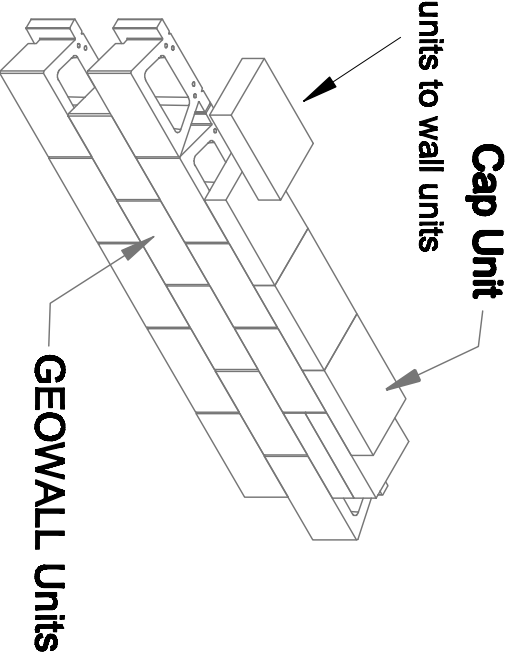

Geogrid is to be placed on level backfill over the fiberglass pins. Place next unit. Pull grid taut and backfill. Stake as required.

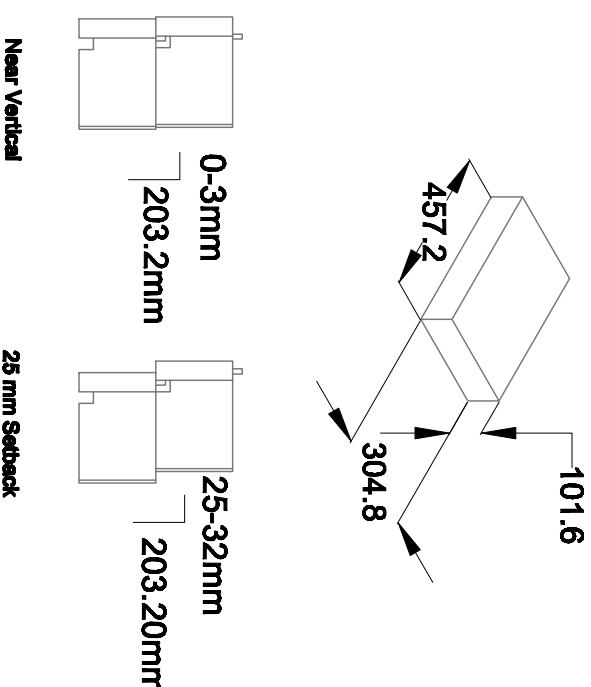
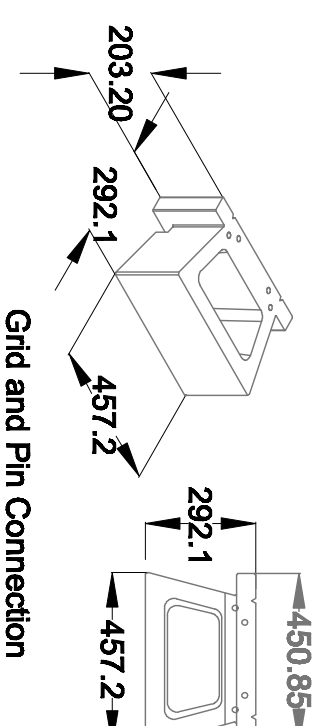
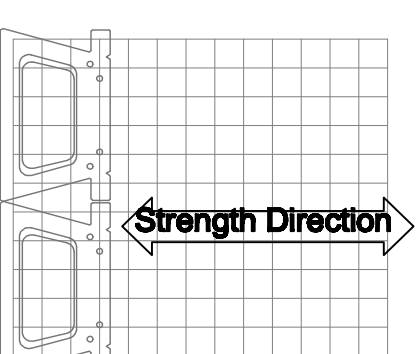

No. Data	Revision	By	Designed By:	Project:	Project No.:
			SAJR	Basalite Standard Drawings	
			Scale:	Title:	Sheet No.
			As Noted	ValleyStone Details	
			Date:		
			02/2/11		